

REEVES VARI-SPEED DRIVES

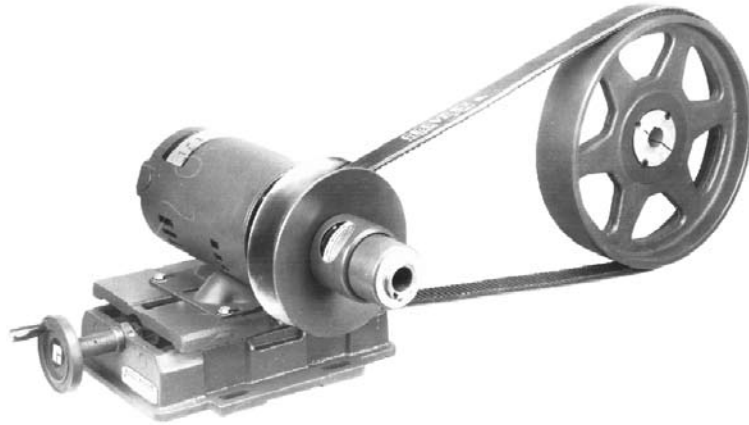

REEVES VARI-SPEED motor pulleys and accessories provide economical, trouble-free adjustable speed drives for the fractional thru 15 HP range. Easy application and rugged design have made these drives a favorite

machinery design option for many years. **Extra-Value** features reduced maintenance time and costs, and contribute to longer belt life and quieter operation.

JUNIOR PULLEY



- 1/4 to 1-1/2 Horsepower
- 2.75 Speed Range
- Easily Lubricated: Contaminants flushed from sliding surfaces
- Patented closed groove lube system with grease reserve
- Uses Standard A or B section belts
- Driven sheave options include FHP or Dual-Duty TAPER-LOCK sheaves
- Fast, simple set-screw mounting



APG

MASTER XL

MOTO DRIVE

ULTIMA

REEVES PULLEYS

REEVES VARI-SPEED DRIVES

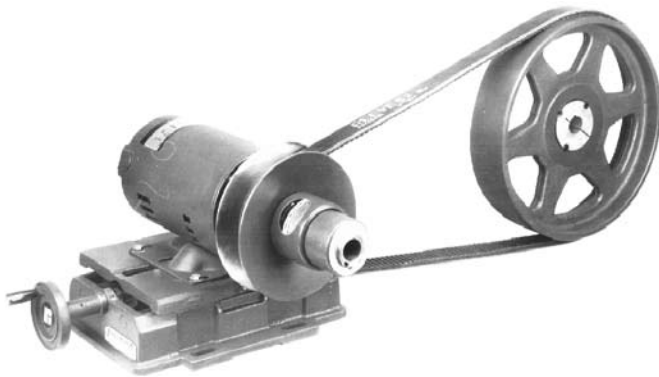

SENIOR PULLEY

- 1/4 to 15 HP
- 3:1 speed range
- Uses industry-standard wide range belts
- Stock TAPER-LOCK flat face pulley is driven sheave
- Self-contained spring cartridge for safety

EXTRA-VALUE FEATURES 1/4 Thru 10 HP Models

ELASTOMERIC BUSHING:

- Eliminates need for lubrication
- Sliding disc rides on tough engineered plastic bushing
- Will not corrode, will not stick
- Quick and easy replacement

CLAMP COLLAR MOUNTING:

- Superior shaft grip
- Collet-style hub secured by compression clamp
- Concentric mount keeps wear and vibration to a minimum
- No fretting corrosion means easy removal for maintenance

DUCTILE IRON DISCS:

- Machined-all-over
- Naturally balanced for smooth running
- Stronger and more wear resistant than cast iron or steel

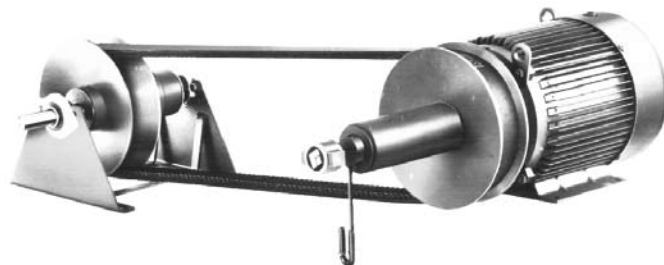

COMPOUND PULLEY

- 1/4 to 5 horsepower
- 9:1 speed range
- Available Countershaft allows C-Flow or Z-Flow configurations
- Manual control of motor pulley for accurate speed adjustment
- Adjustable motor base not required